



# MAX8632 Evaluation Kit

## General Description

The MAX8632 evaluation kit (EV kit) is designed to evaluate the MAX8632 DDR power-supply solution for notebooks, desktops, and graphics cards. The EV kit board produces VDDQ at the output of the synchronous PWM buck, VTT at the output of the sourcing/sinking LDO linear regulator, and VTTR at the output of the reference buffer.

The VDDQ output is preset to 1.8V and sources up to 10A. The VTT output is always VDDQ/2 and can source/sink up to 3A of peak current and 1.5A of continuous current. The VTTR output is also always VDDQ/2 and can source/sink up to 10mA.

The MAX8632 EV kit was conveniently designed with jumpers to select the OVP/UV, TON, SKIP, STBY, and SHDN modes. The board's default settings enable OVP (overvoltage protection), 300kHz switching frequency, low-noise PWM mode, VDDQ, VTT, and VTTR.

The VIN input accepts voltages from 7V to 20.5V and VDD requires a 5V bias supply.

## Features

- ◆ VDDQ Preset to 1.8V/10A
- ◆ VTT 0.9V Source/Sink 1.5A Continuous/3A Peak
- ◆ VTTR 0.9V Source/Sink 10mA
- ◆ VIN Range: 7V to 20.5V
- ◆ Optimized Switching Frequency: 300kHz
- ◆ Overvoltage/Undervoltage Protection
- ◆ Independent Shutdown and Standby Controls
- ◆ Power OK

## Ordering Information

PART	TEMP RANGE	IC PACKAGE
MAX8632EVKIT	0°C to +70°C	28 Thin QFN 5mm x 5mm

## Component List

DESIGNATION	QTY	DESCRIPTION
C1	1	0.1μF ±10%, 16V X7R (0603) ceramic capacitor Taiyo Yuden EMK107BJ104MA
C2, C4A, C4B	3	10μF ±10%, 6.3V X5R (0805) ceramic capacitors Kemet C0805C106K9PAC Taiyo Yuden JMK212BJ106MG
C3, C6	2	1μF ±10%, 10V X5R (0603) ceramic capacitors TDK C1608X5R1A105K
C5	1	4.7μF ±20%, 6.3V (0805) X5R ceramic capacitor TDK C2012X5R0J475M
C7, C10	2	0.22μF ±20%, 16V X7R (0603) ceramic capacitors TDK C1608X7R1C224M
C8A, C8B, C8C	3	10μF ±20%, 25V X5R (1210) ceramic capacitors Taiyo Yuden TMK325BJ106MM TDK C3225X5R1E106M

DESIGNATION	QTY	DESCRIPTION
C9	1	4700pF ±10%, 50V X7R (0603) ceramic capacitor Kemet C0603C472K5RAC or equivalent
C11, C12	2	150μF, 4V, 18mΩ POS capacitors Sanyo 4TPE150MI
D1	1	Schottky diode, 30V, 100mA (SOD-323) Central CMDSH-3
JU1–JU4, JU6	5	3-pin headers, 0.1in center 36-pin header, 0.1in center Sullins PTC36SAAN or equivalent Digi-key S1012-36-ND
L1	1	1.4μH, 15.5A, 2.8mΩ power inductor Sumida CEP125-1R4MC-U
Q1	1	30V, 12mΩ (SO-8) n-channel MOSFET International Rectifier IRF7821
Q2	1	30V, 4mΩ (SO-8) n-channel MOSFET International Rectifier IRF7832

# MAX8632 Evaluation Kit

## Component List (continued)

DESIGNATION	QTY	DESCRIPTION
R1	1	10 $\Omega$ $\pm$ 5% (0603) resistor
R2, R3, R4	3	100k $\Omega$ $\pm$ 5% (0603) resistors
R5	1	36.5k $\Omega$ $\pm$ 1% (0603) resistor
R13	1	20 $\Omega$ $\pm$ 5% (0603) resistor
R18	1	0 $\Omega$ $\pm$ 5% (0603) resistor
U1	1	Integrated DDR power supply (28-pin, 5mm x 5mm, Thin QFN) MAX8632ETI+
—	5	Shunts Sullins STC02SYAN Digi-key S9000-ND or equivalent

## Component Suppliers

SUPPLIER	PHONE	WEBSITE
Central Semiconductor	631-435-1110	www.centrasemi.com
International Rectifier	310-322-3331	www.irf.com
Kemet	864-963-6300	www.kemet.com
Sanyo USA	619-661-6835	www.sanyo.com
Sumida	847-545-6700	www.sumida.com
Taiyo Yuden	800-348-2496	www.t-yuden.com
TDK	847-803-6100	www.component.tdk.com

**Note:** Indicate that you are using the MAX8632 when contacting these component suppliers.

## Recommended Equipment

- 5VDC power supply (500mA rated)
- 7VDC to 20.5VDC power supply (5A rated)
- Two digital voltmeters (DVM)

## Quick Start

The MAX8632 EV kit is fully assembled and tested. Follow these steps to verify board operation. **Do not turn on the power supplies until all connections are completed.**

- 1) Ensure a shunt is placed across pins 1-4 of jumper JU2 to enable OVP and UVP.
- 2) Ensure jumper JU1 is open to set the switching frequency to approximately 300kHz.

- 3) Ensure a shunt is placed across pins 1-2 of jumper JU3 to enable low-noise PWM mode.
- 4) Ensure a shunt is placed across pins 2-3 of jumper JU4 to disable the VDDQ buck output.
- 5) Ensure a shunt is placed across pins 2-3 of jumper JU6 to set the board in normal operation mode.
- 6) Connect the 5VDC power supply across the VDD pad and the GND pad nearest VIN.
- 7) Connect the 12VDC power supply across the VIN pad and the corresponding GND pad.
- 8) Turn on both of the power supplies.
- 9) Set JU4 (1-2). This turns VDDQ on.
- 10) Using one of the DVMs, verify that the VDDQ voltage between the VDDQ and PGND pads is 1.8V ( $\pm$ 2%).
- 11) Using the other DVM, verify that the VTT voltage between the VTT and PGND pads is 0.9V ( $\pm$ 2%).

## Detailed Description

### Jumper Selection

**Table 1. Overvoltage/Undervoltage Control Input (OVP/UVP)**

JUMPER	SHUNT POSITION	DESCRIPTION
JU2	1-2	Disable OVP and UVP.
JU2	1-3	Enable UVP. Disable OVP.
JU2	1-4*	Enable OVP and UVP.
JU2	Open	Enable OVP. Disable UVP.

\*Default position.

**Note:** Refer to the MAX8632 data sheet for additional information on OVP/UVP.

### Setting the Buck Regulator Output Voltage (VDDQ)

The output voltage of the buck regulator is preset to 1.8V on the MAX8632 EV kit for DDR memory applications. To pin-strap the output voltage to 2.5V, follow the steps below:

- 1) Remove R18.
  - 2) Solder the 0 $\Omega$  resistor from step 1 in the R9 location.
- Refer to the MAX8632 data sheet to change the external components for optimum performance.

# MAX8632 Evaluation Kit

Evaluates: MAX8632

**Table 2. On-Time Selection Input (TON)**

JUMPER	SHUNT POSITION	DESCRIPTION
JU1	1-2	600kHz switching frequency
JU1	1-3	450kHz switching frequency
JU1	1-4	200kHz switching frequency
JU1	Open*	300kHz switching frequency

\*Default position.

**Note:** Refer to the MAX8632 data sheet for additional information on TON.

**Table 3. Pulse-Skipping Control Input (SKIP)**

JUMPER	SHUNT POSITION	DESCRIPTION
JU3	1-2*	Low-noise PWM mode.
JU3	2-3	Pulse-skipping mode.

\*Default position.

**Note:** Refer to the MAX8632 data sheet for additional information on SKIP.

**Table 4. Shutdown Control Input ( $\overline{\text{SHDN}}$ )**

JUMPER	SHUNT POSITION	DESCRIPTION
JU4	1-2	The VDDQ buck output is enabled.
JU4	2-3*	The VDDQ buck output is shut down.

\*Default position.

**Note:** Refer to the MAX8632 data sheet for additional information on SHDN.

**Table 5. Standby Control Input ( $\overline{\text{STBY}}$ )**

JUMPER	SHUNT POSITION	DESCRIPTION
JU6	2-3	The VTT output is shut down.
JU6	1-2*	Normal operation.

\*Default position.

**Note:** Refer to the MAX8632 data sheet for additional information on STBY.



# MAX8632 Evaluation Kit

Evaluates: MAX8632

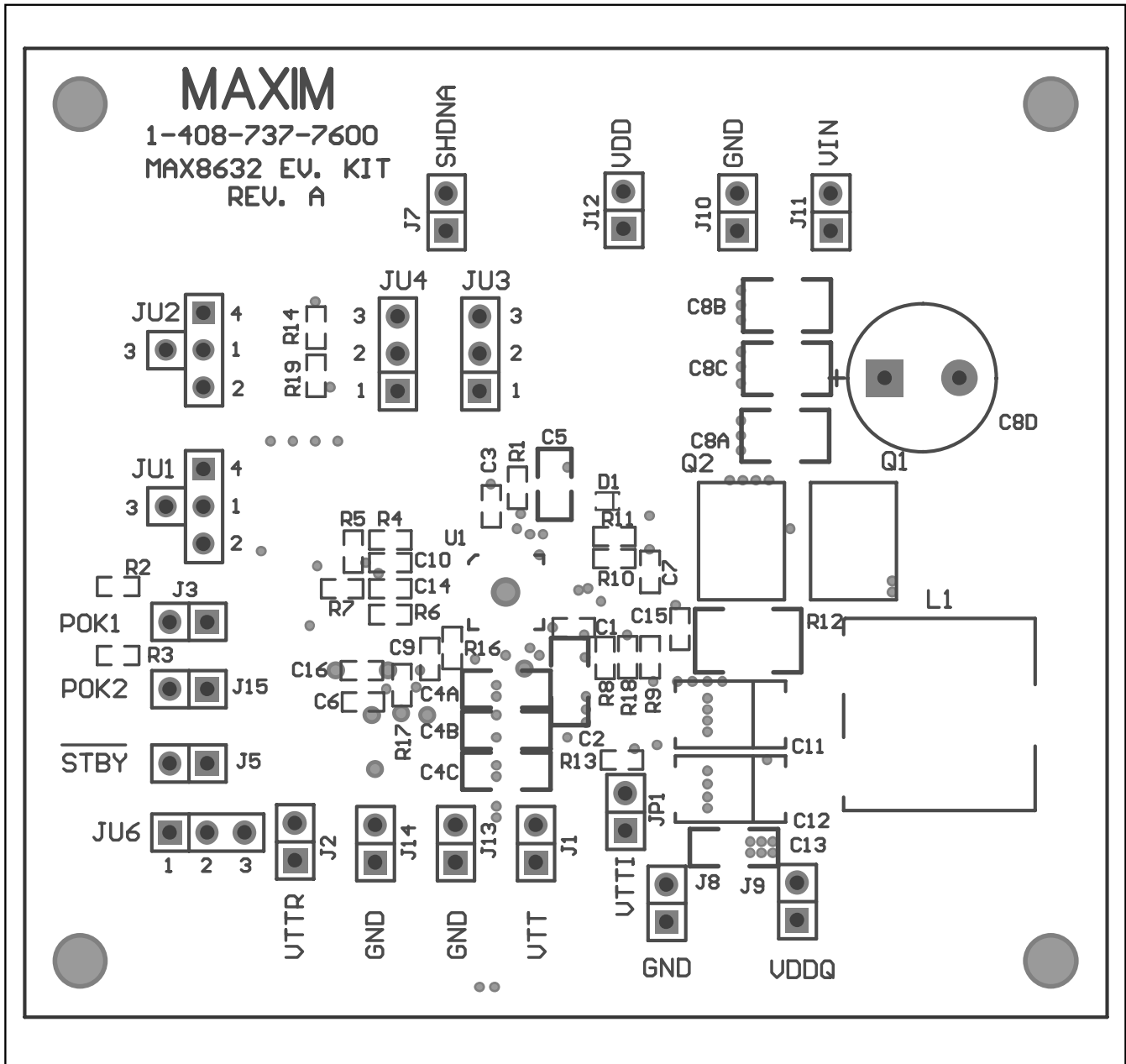

Figure 2. MAX8632 EV Kit Component Placement Guide—Component Side

# MAX8632 Evaluation Kit

Evaluates: MAX8632

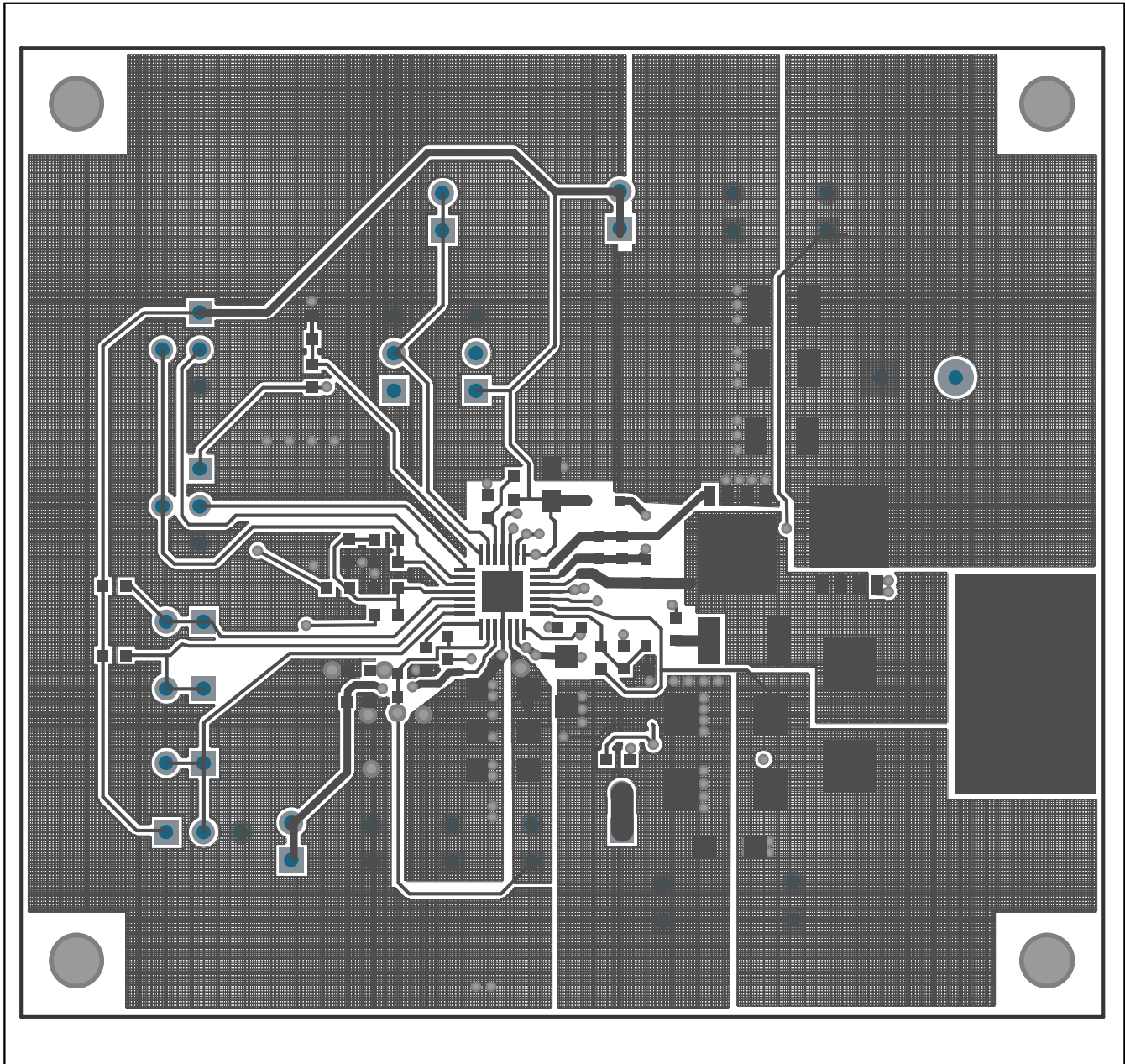

Figure 3. MAX8632 EV Kit PC Board Layout—Component Side

# MAX8632 Evaluation Kit

Evaluates: MAX8632

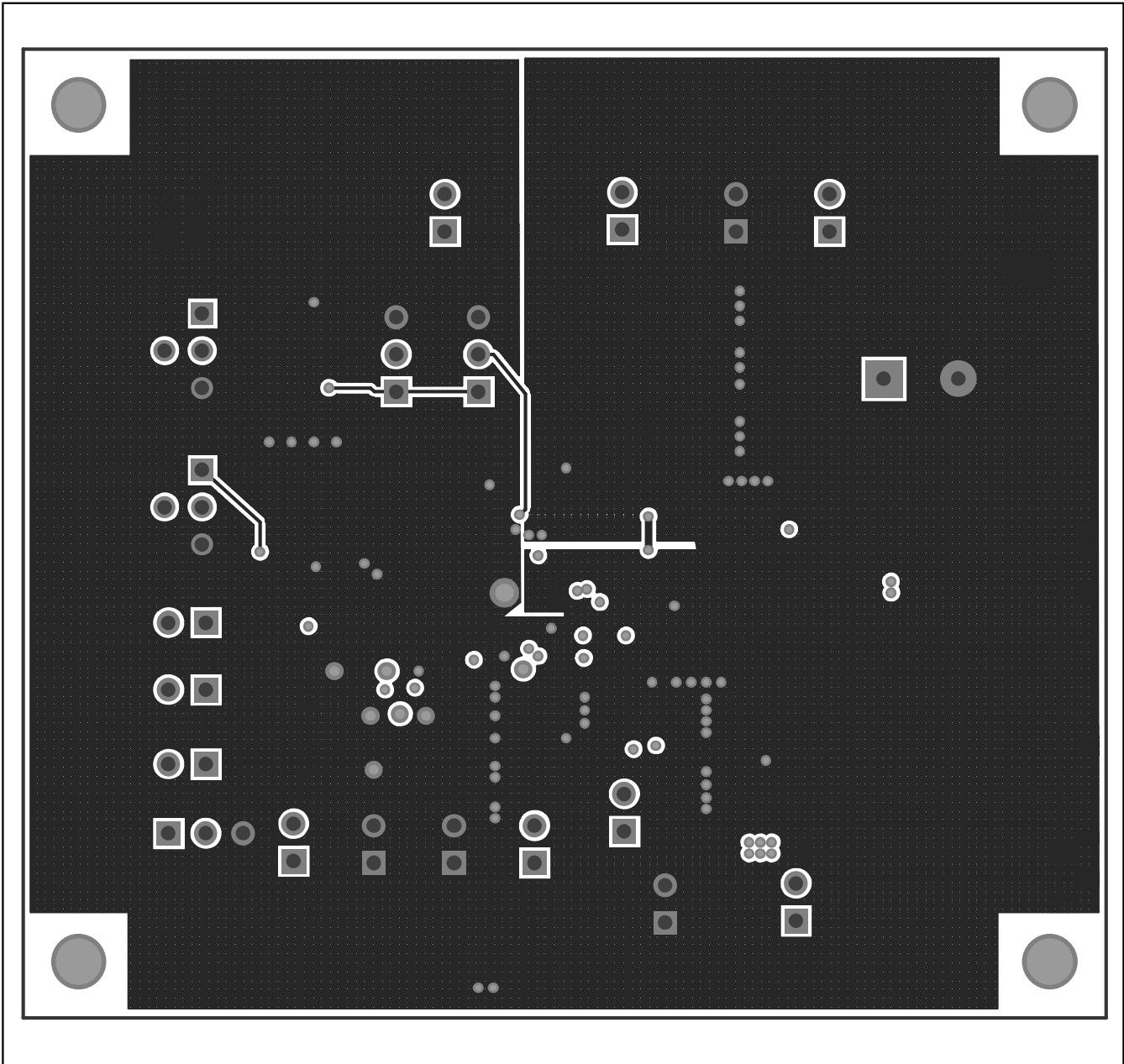

Figure 4. MAX8632 EV Kit PC Board Layout—Inner Layer 2

# MAX8632 Evaluation Kit

**Evaluates: MAX8632**

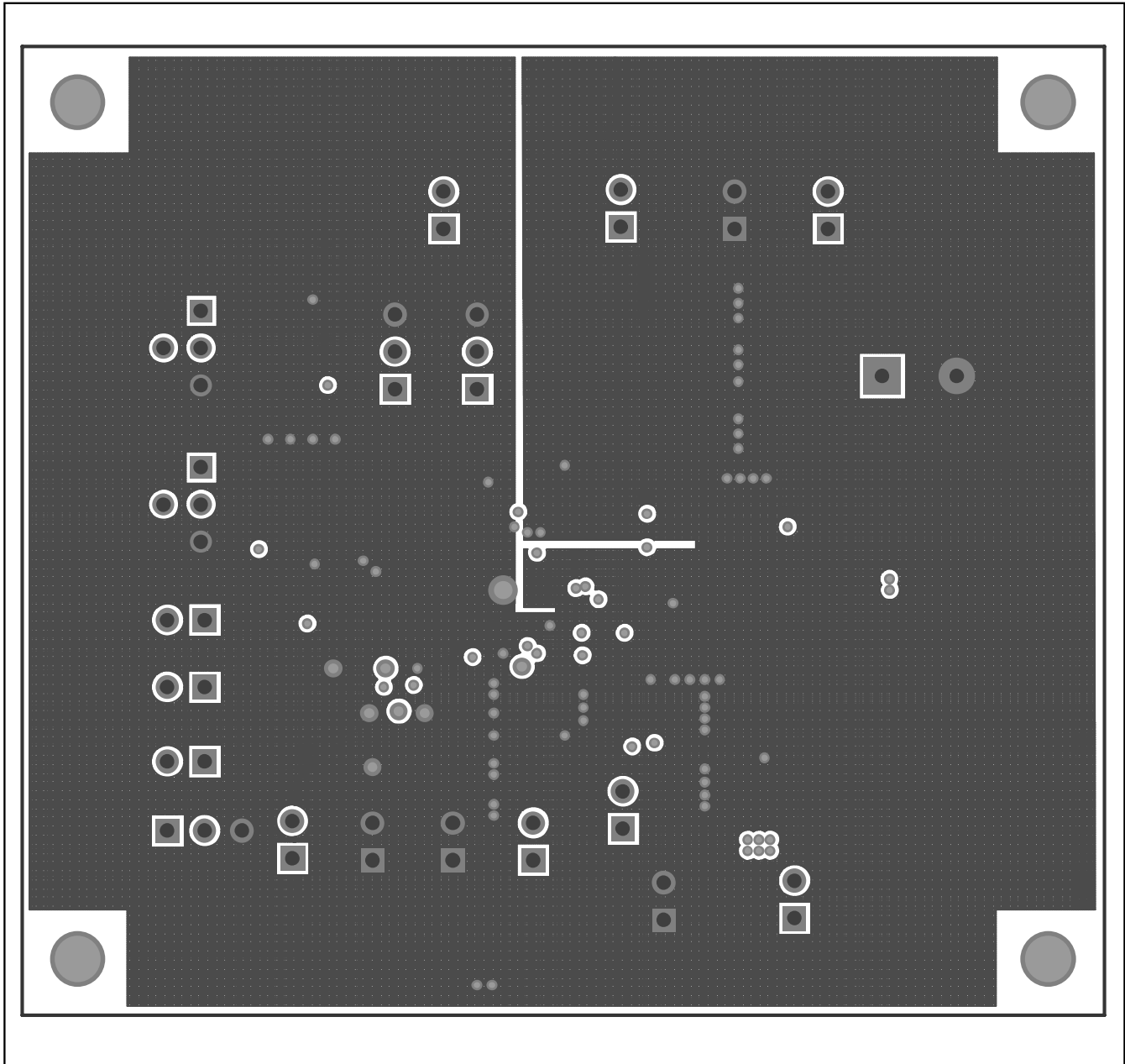

Figure 5. MAX8632 EV Kit PC Board Layout—Inner Layer 3



# MAX8632 Evaluation KiMAX8632 Evaluation Kit

Evaluates: MAX8632

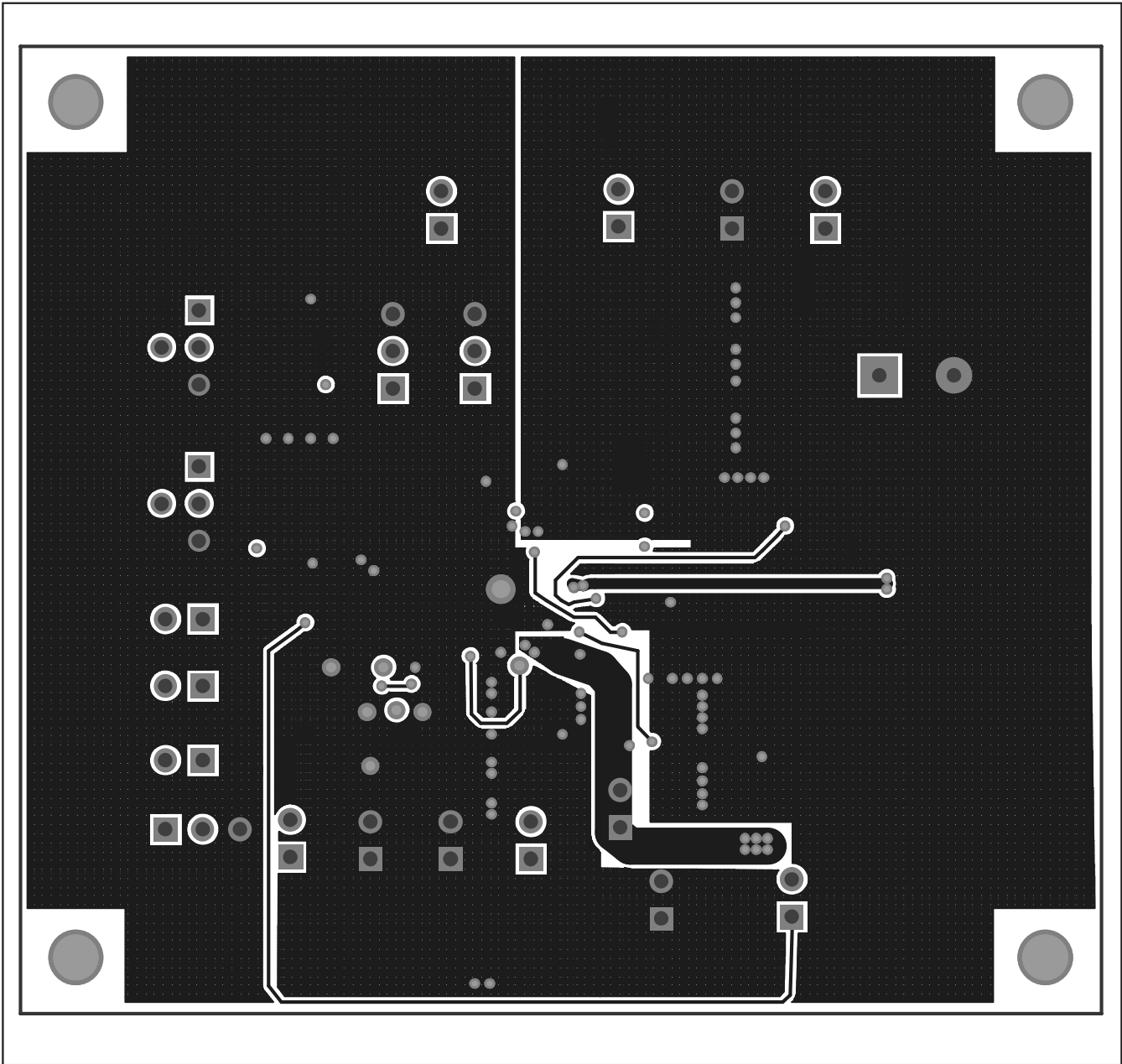

Figure 6. MAX8632 EV Kit PC Board Layout—Solder Side

Maxim cannot assume responsibility for use of any circuitry other than circuitry entirely embodied in a Maxim product. No circuit patent licenses are implied. Maxim reserves the right to change the circuitry and specifications without notice at any time.

Maxim Integrated Products, 120 San Gabriel Drive, Sunnyvale, CA 94086 408-737-7600 \_\_\_\_\_ 9